

**MODEL****XC**

## HOPPER SHAPE KNIFE GATE VALVE

The XC model knife gate is a uni-directional wafer valve designed for industrial bulk handling service applications (powdered and granular products). The special design of the body allows for easy passage of the fluid and makes it ideal for use as silo outlet valve. Widely used in industries such as:

- Power plants
- Chemical plants
- Mining
- Food and Beverage
- Etc.

Valve is usually installed under silos or hoppers in vertical pipes with the seat in the upstream side of the valve in order to protect it from the solids flow. This set up helps to protect the seat from premature wear and gate jamming due to solid build-up.

### Sizes:

DN 50 to DN 600 (larger diameters on request)

### Working pressure:

DN 50 to DN 250	10 bar
DN 300 to DN 400	6 bar
DN 450	5 bar
DN 500 to DN 600	4 bar

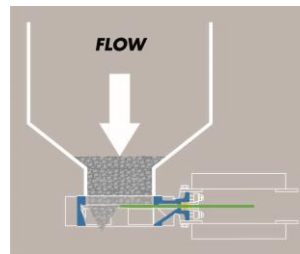

For specific tightness requirements contact ORBINOX technical department

### Standard flange connection:

DIN PN 10 and ANSI B16.5 (class 150)

Note: other flange connections are available on request

### Directives:

For EU Directives and other Certificates, please see the document:

Directives and Certificates Compliance - Knife Gate Valves - Catalogues and Datasheets

All valves are tested prior to shipping in accordance with the standard developed by the Quality Control Department at ORBINOX

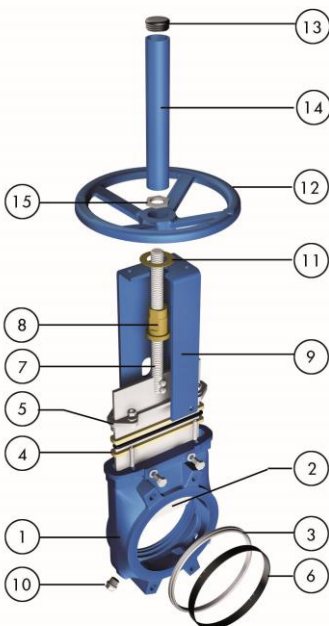

### STANDARD PARTS LIST

Part:	Cast Iron:	Stainless Steel:
1- Body	GJL 250 (GG25)	CF8M
2- Gate	AISI 304	AISI 316
3- Seat	Metal or EPDM	
4- Packing	PTFE Impreg. Synth. Fibre (with an EPDM o-ring)	
5- Gland Follower	Aluminium (DN 50-300) Ductile Iron (DN 350-600)	CF8M
6- Seat retainer ring	AISI 304	AISI 316
7- Stem	Stainless Steel	
8- Stem nut	Brass	
9- Yoke	Epoxy-coated Carbon Steel	
10- Cleaning	Carbon Steel	
11- Friction washer	Brass	
12- Handwheel	GJS400 (GGG40)	
13- Cap	Plastic	
14- Stem Protector	Epoxy-coated Carbon Steel	
15- Nut	Zinc plated Carbon Steel	

ООО «ТИ-СИСТЕМС» ИНЖИНИРИНГ И ПОСТАВКА ТЕХНОЛОГИЧЕСКОГО ОБОРУДОВАНИЯ

Интернет: [www.tisys.ru](http://www.tisys.ru) [www.tisys.kz](http://www.tisys.kz) [www.tisys.by](http://www.tisys.by) [www.tesec.ru](http://www.tesec.ru) [www.ти-системс.рф](http://www.ти-системс.рф)

Телефоны: +7 (495) 7774788, 7489626, (925) 5007155, 54, 65 Эл. почта: [info@tisys.ru](mailto:info@tisys.ru) [info@tisys.kz](mailto:info@tisys.kz) [info@tisys.by](mailto:info@tisys.by)

MODEL

XC



## DESIGN FEATURES

### **BODY:**

Wafer style cast monoblock design for installation between raised face flanges, with reinforced ribs in larger diameters for extra body strength. Internal cast gate wedges and guides allow for tighter shut-off. Special cast gate supports ensure permanent contact between the gate and the seat when the valve is installed in the reverse position of the flow direction. The wide face to face distance as well as the internal design with the integrated flushing corners avoid any build up of solids that would prevent the valve from closing. Full port design for greater flow capacity and minimal pressure drop. The standard flush ports allow the cleaning of solids trapped within the body cavities that can obstruct the flow or the sealing in the closed position. Depending on the media, the purge ports can be injected with air, steam, liquids, etc.

### **GATE:**

Stainless steel rectangular shape gate. Gate is polished on both sides to avoid jamming and seat damage. Bottom of the gate edge is machined to a bevel to cut through solids for a tighter seal in the closed position. The thickness and/or material of the gate can be changed on request for higher pressure requirements.

### **SEAT: (resilient)**

Unique design that mechanically locks the seal in the internal of the valve body with a stainless steel retainer ring. Standard EPDM also available in different materials such as Viton, PTFE, etc.

### **PACKING:**

Long-life packing with several layers of braided fibre plus an EPDM o-ring, with an easy access packing gland ensuring a tight seal. Long-life braided packing is available in a wide range of materials.

### **STEM:**

The standard stainless steel stem offers a long corrosion resistant life. For rising stem handwheel actuators only, a stem protector is provided for additional protection against dust while the valve is in the open position.

### **ACTUATORS:**

All actuators supplied by ORBINOX are interchangeable, and supplied with an standard mounting kit for installation purposes on site.

### **YOKE or ACTUATOR SUPPORT:**

Made of EPOXY coated steel (stainless steel available on request). Compact design makes it extremely robust even under the most severe conditions. Reinforced design is standard starting from DN 250.

### **EPOXY COATING:**

The epoxy coating on all ORBINOX cast iron and carbon steel valve bodies and components is electrostatically applied making the valves to be corrosion resistant with a high quality finished surface. The ORBINOX standard colour is RAL-5015 blue.

### **GATE SAFETY PROTECTION:**

ORBINOX automated valves are provided with gate guards in accordance with EU Safety Standards. The design feature prevents any objects from being caught accidentally while the gate is moving.



MODEL

XC

## OTHER OPTIONS

### Bonnet (Fig.1):

Assures tight sealing to atmosphere for use with hazardous gas or fluids. Reduces packing maintenance

### Other materials of construction:

Special alloys such as AISI 317 (1.4449), 254SMO (1.4547), Hastelloys, etc.

### Fabricated valves:

ORBINOX designs, produces and delivers special fabricated valves for special process conditions (big sizes, high pressures, materials of construction, etc.)

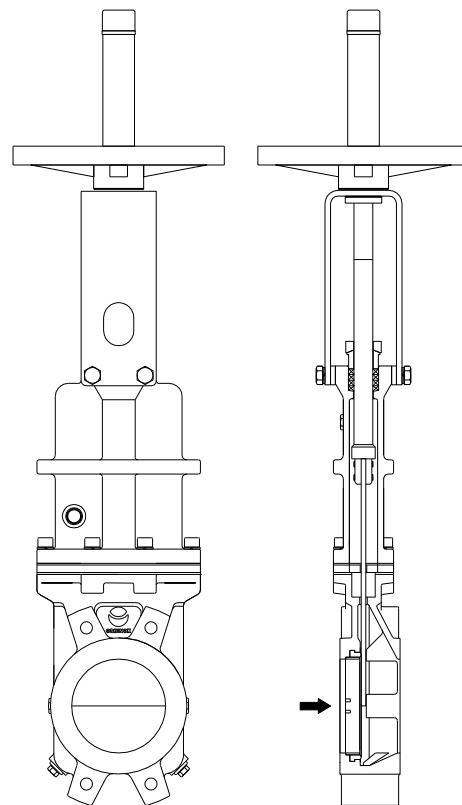

Fig.1

## SURFACE TREATMENTS

Valve components can be protected or coated for a longer life expectancy, depending on the application and the service conditions.

At ORBINOX we can offer treatments and coatings for the valve components to improve the properties against abrasion (Stellite, polyurethane...), corrosion (Halar, Rilsan, galvanised...) and adherence (polishing, PTFE...)

MODEL

XC

## ACTUATOR TYPES

### MANUAL:

Handwheel (rising & non-rising stem)  
Chainwheel  
Lever  
Bevel Gear (rising & non-rising stem)  
Others (square nut...)

### AUTOMATIC:

Electric (rising & non-rising stem)  
Pneumatic (single & double-acting)  
Hydraulic

All actuators supplied by ORBINOX are interchangeable

## FAIL SAFE SYSTEMS

Used on pneumatic actuated valves

### SINGLE ACTING (SPRING RETURN)

- Available from DN 50 to DN 300
- Supply pressure:  
min. 5 bar - max. 10 bar
- Options:
  - Fail open
  - Fail close

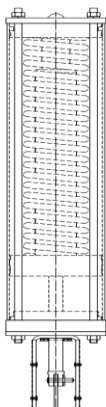

### DOUBLE ACTING WITH AIR TANK

- Available for all valve sizes
- Supply pressure:  
min. 3.5 bar - max. 10 bar
- Options:
  - Pneumatic Failsafe
  - Pneumatic or Electric Failsafe

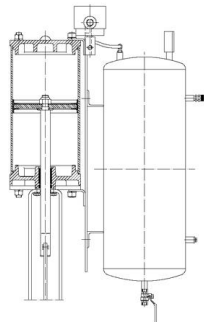

## ACCESSORIES

Mechanical stops  
Locking device  
Manual override  
Solenoid valves  
Positioners  
Limit switches  
Proximity switches  
Floor stands  
Stem extensions

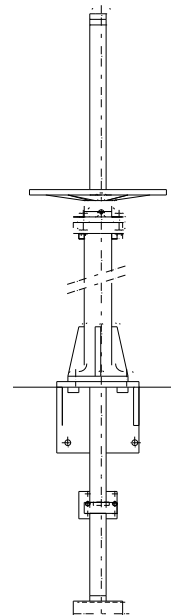

Wide range of valve extensions available

*For further information about fail safe systems and valve extensions, please see EX catalogue*

We recommend to contact our technical department

## TEMPERATURE CHART

### SEAT / SEALS

### PACKING

Material	Max.Temp.(°C)	Applications
Metal/Metal	>250	High temp./Low tightness
EPDM (E)	120	Acids and non mineral oils
NBR (N)	120	Resistance to petroleum products
FKM-FPM (V)	200	Chemical service/High temp.
VMQ (S)	250	Food service/High temp.
PTFE (T)	250	Corrosion resistance

Material	Max.Temp.(°C)	pH
PTFE impregn. synth. fibre (ST)	250	2-13
Braided PTFE (TH)	260	0-14
Graphited (GR)	600	0-14
Ceramic fibre (FC)	1200	--

NOTE: all types include an elastomere O-ring (same material as seal), excluding TH, GR and FC

More details and other materials under request

## SEAT TYPES

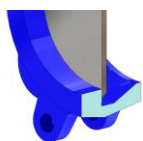

### METAL/METAL

For applications with:

- High temperature
- High density media application
- Full tightness not required

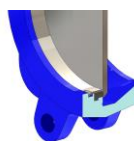

### RESILIENT TYPE "A"

- Standard resilient seat
- Temperature limitations according to the selected seat material. Review the above chart or contact our Technical Department for more information
- Seat with replaceable retainer ring

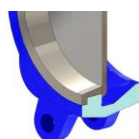

### TYPE "B" SEAT (metal/metal)

For applications with:

- High temperature
- High density media application
- Full tightness is not required
- Replaceable design without disassembling the valve

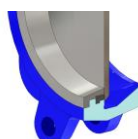

### TYPE "B" SEAT (resilient)

- Temperature limitations according to the selected seat material. Review the above chart or contact our Technical Department for more information
- Replaceable and reinforced seat ring available in different materials such as: stainless steel, CA15, Ni Hard,...

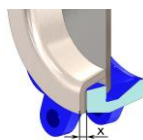

### DEFLECTION CONE "C"

- Deflects the media away from any valve internal exposed parts (gate guides, seat,...)
- Material: AISI 316, CA15, Ni-Hard, etc.
- Face-to-face dimension increases:
  - DN 50 to DN 250 X = 9mm
  - DN 300 to DN 600 X = 12mm
- Larger diameters on request

**MODEL****XC**

## HANDWHEEL (rising stem)

- Standard manual actuator
- Consists of:
  - Handwheel: Epoxy coated Cast Iron
  - Stem
  - Stem nut
  - Stem protector
- Available from DN 50 to DN 600
- Options (on request):
  - Locking Device
  - Extensions and floor stands

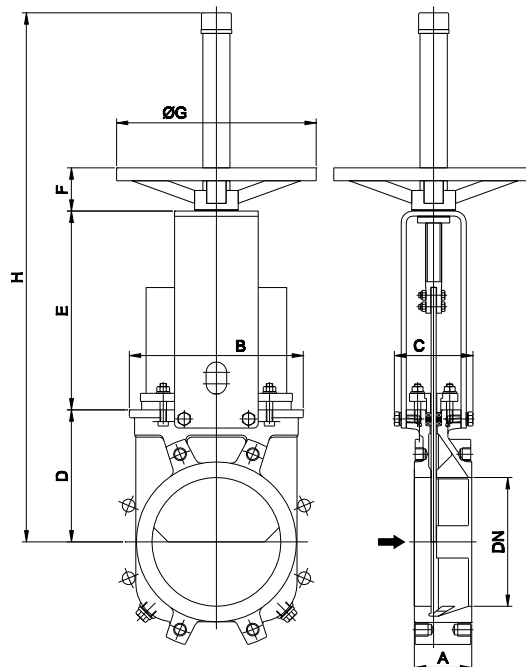

DN	A	B	C	D	E	F	ØG	H	Weight (kg.)
50	46	124	100	105	129	47	225	420	7
65	46	139	100	115	146	47	225	450	8
80	64	154	100	124	162	47	225	475	9
100	64	174	100	140	187	47	225	520	11
125	70	192	100	150	211	47	225	600	15
150	76	217	100	170	237	47	225	647	18
200	89	270	122	205	309	67	310	822	30
250	114	326	170	240	364	67	310	1012	44
300	114	380	170	280	414	67	310	1102	58
350	127	438	170	320	486	66	410	1305	96
400	140	493	170	350	536	66	410	1385	124
450	152	546	170	420	588	66	550	1582	168
500	152	620	170	450	648	66	550	1672	192
600	178	714	170	530	748	66	550	1962	245

**HANDWHEEL (non-rising stem)**

- Recommended for installation where space is limited

- Consists of:
  - Handwheel
  - DN 50-300: Aluminium
  - DN ≥ 350: GJS400 (GGG40)
  - Stem
  - Yoke bushing
  - Stem nut fixed to the gate

- Available from DN 50 to DN 600

- Options (on request):
  - Locking Device
  - Extensions and floor stands
  - Square Nut Drive

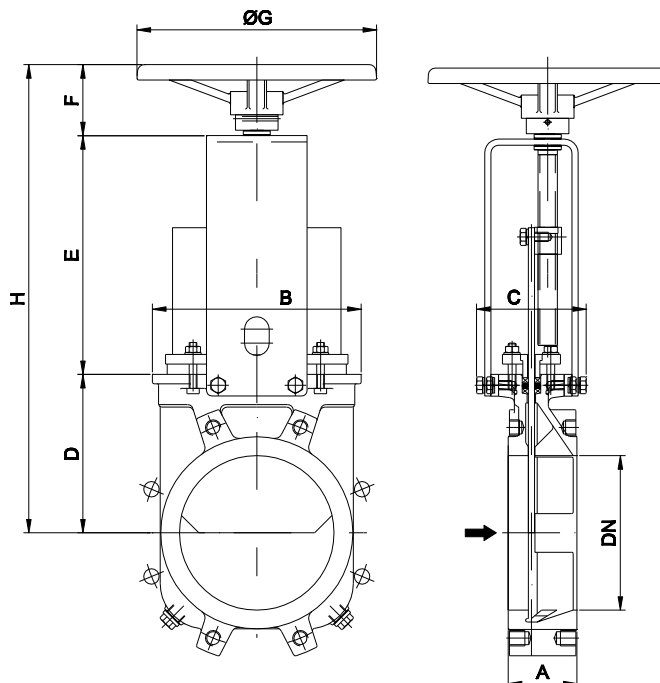

DN	A	B	C	D	E	F	ØG	H
50	46	124	125	105	144	63	225	312
65	46	139	125	115	161	63	225	339
80	64	154	125	124	177	63	225	364
100	64	174	125	140	202	63	225	405
125	70	192	125	150	226	63	225	439
150	76	217	125	170	252	63	225	485
200	89	270	142	205	317	73	310	595
250	114	326	170	240	372	73	310	685
300	114	380	170	280	422	73	310	775
350	127	438	170	320	509	98	410	927
400	140	493	170	350	559	98	410	1007
450	152	546	170	420	611	98	550	1129
500	152	620	170	450	671	98	550	1219
600	178	714	170	530	771	98	550	1399

## CHAINWHEEL (rising stem)

- Recommended for elevated installations
- Consists of:
  - Chainwheel: Epoxy coated Cast Iron
  - Stem
  - Stem nut
  - Stem protector
- Available from DN 50 to DN 600
- Options:
  - Locking Device
  - Extension and floor stands
  - Non-rising Stem

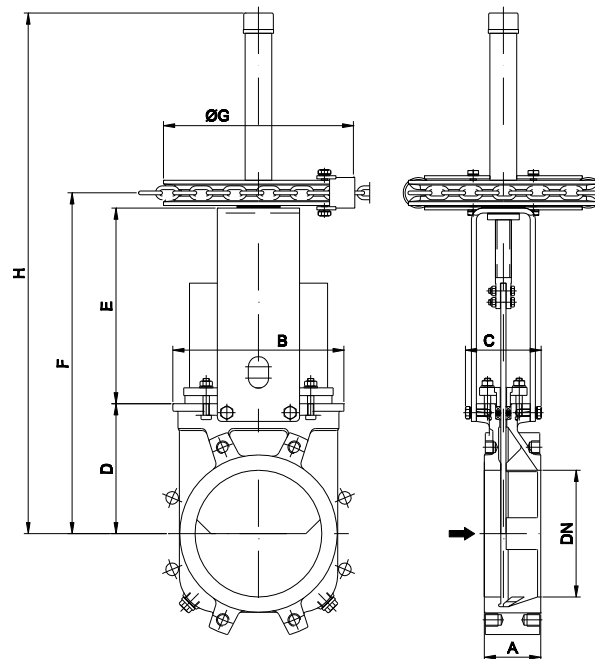

DN	A	B	C	D	E	F	ØG	H
50	46	124	100	105	129	253	225	424
65	46	139	100	115	146	280	225	451
80	64	154	100	124	162	305	225	476
100	64	174	100	140	187	347	225	518
125	70	192	100	150	211	380	225	601
150	76	217	100	170	237	426	225	647
200	89	270	122	205	309	538	300	822
250	114	326	170	240	364	628	300	1012
300	114	380	170	280	414	718	300	1102
350	127	438	170	320	486	838	454	1305
400	140	493	170	350	536	918	454	1385
450	152	546	170	420	588	1040	454	1577
500	152	620	170	450	648	1130	454	1662
600	178	714	170	530	748	1310	454	1962



**LEVER**

- Recommended for quick opening and closing
- Consists of:
  - Lever
  - Stem
  - Yoke Sleeve
  - Lever Lock
- Available from DN 50 to DN 300

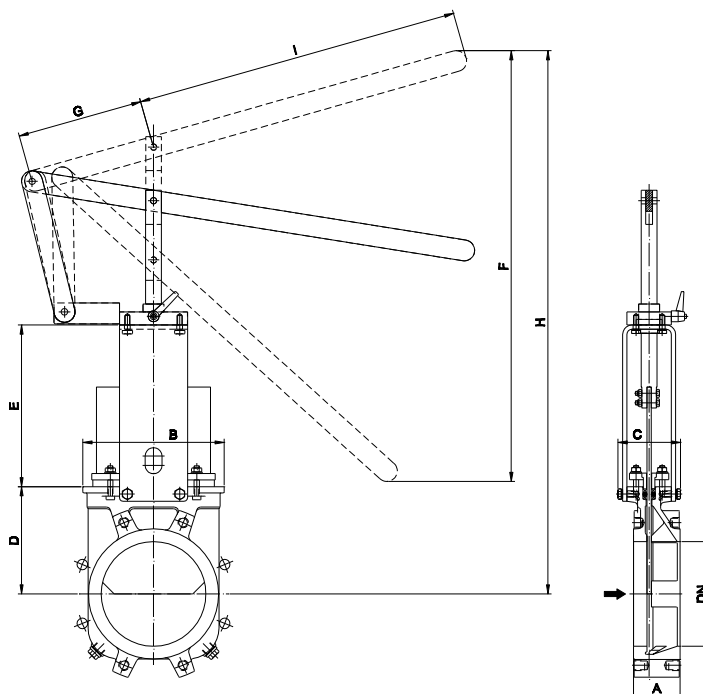

DN	A	B	C	D	E	F	G	H	I
50	46	124	100	105	129	256	150	408	315
65	46	139	100	115	146	259	150	435	315
80	64	154	100	124	162	307	150	509	315
100	64	174	100	140	187	378	150	637	415
125	70	192	100	150	211	439	150	755	415
150	76	217	100	170	237	529	150	890	415
200	89	270	122	205	309	620	235	1038	620
250	114	326	170	240	364	822	235	1297	620
300	114	380	170	280	414	995	235	1558	620

## GEAR (rising stem)

- Recommended for valves larger than DN 350 and working pressures greater than 3.5 bar
- Consists of:
  - Stem
  - Yoke
  - Bevel Gear Actuator with Handwheel (Standard Ratio 4:1)
- Available from DN 200 to DN 600
- Options:
  - Locking device
  - Extension
  - Chainwheel
  - Non-rising stem

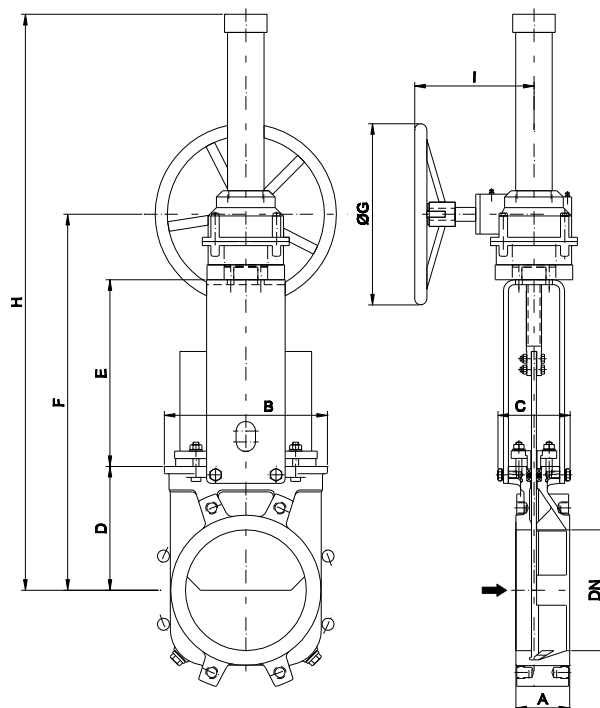

DN	A	B	C	D	E	F	ØG	H	I
200	89	270	122	205	309	623	300	964	198
250	114	326	170	240	364	713	300	1054	198
300	114	380	170	280	414	803	300	1144	198
350	127	438	170	320	500	904	450	1545	218
400	140	493	170	350	550	984	450	1626	218
450	152	546	170	420	598	1102	450	1742	218
500	152	620	170	450	658	1192	450	1833	218
600	178	714	170	530	758	1372	450	2014	218

**PNEUMATIC CYLINDER**

- The standard pneumatic actuator (double acting on-off cylinder) consists of:
  - $\varnothing \leq 300$ : Aluminum barrels
  - $\varnothing \geq 350$ : Composite barrels
  - Aluminum end covers
  - Stainless Steel (AISI 304) piston rod
  - Nitrile coated steel piston
- Available from DN 50 to DN 600
- Supply Pressure: min. 3.5 bar - max. 10 bar. Actuator designed with 6 bar air supply
- Reinforced yoke is standard starting from DN250
- Options (on request):
  - Hard anodized barrel and covers
  - Stainless Steel barrel and covers
  - Over/Undersized cylinder
  - Manual override
  - Fail safe system
  - Limit switches
- Instrumentation (on request):
  - Positioners
  - Solenoid valves
  - Flow regulators
  - Air preparation units

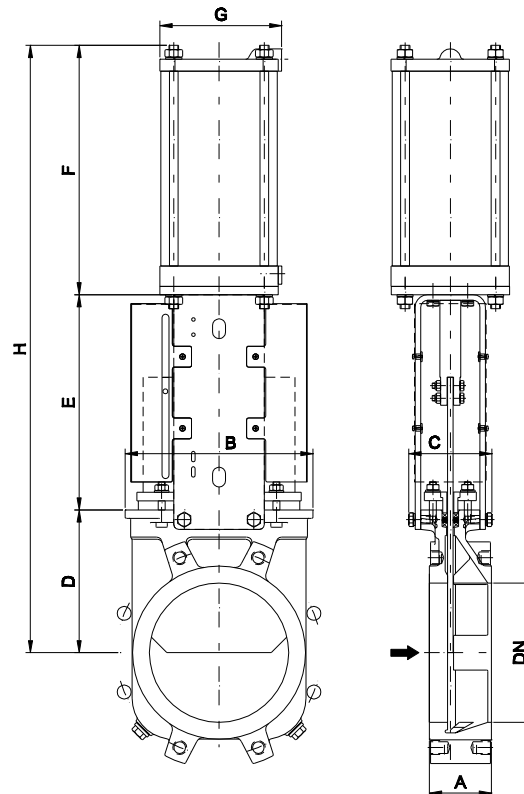

DN	A	B	C	D	E	F	G	H	Weight (kg.)	Standard Cyl.	Connect.
50	46	124	100	105	129	178	115	412	9	C100/62	1/4" G
65	46	139	100	115	146	193	115	454	10	C100/77	1/4" G
80	64	154	100	124	162	211	115	497	11	C100/95	1/4" G
100	64	174	100	140	187	231	115	558	14	C100/115	1/4" G
125	70	192	100	150	211	271	140	632	20	C125/143	1/4" G
150	76	217	100	170	237	296	140	703	25	C125/168	1/4" G
200	89	270	122	205	309	358	175	872	44	C160/220	1/4" G
250	114	326	170	240	364	428	220	1032	67	C200/270	3/8" G
300	114	380	170	280	414	478	220	1172	82	C200/320	3/8" G
350	127	438	170	320	500	549	277	1369	135	C250/375	3/8" G
400	140	493	170	350	550	599	277	1499	165	C250/425	3/8" G
450	152	546	170	420	598	680	382	1698	220	C300/475	1/2" G
500	152	620	170	450	658	730	382	1838	280	C300/525	1/2" G
600	178	714	170	530	758	830	382	2128	330	C300/625	1/2" G

**MODEL****XC**

## ELECTRIC ACTUATOR (rising stem)

- Consists of:
  - Electric motor
  - Motor support yoke flange (acc. to ISO 5210/DIN 3338)
  
- The standard electric motor is equipped with:
  - Manual emergency operation
  - Limit switches (open/closed)
  - Torque switches
  
- Available from DN 50 to DN 600
  
- Reinforced yoke is standard starting from DN250
  
- Wide range of types and marks available to meet customer's needs.
  
- Option:
  - Non rising stem

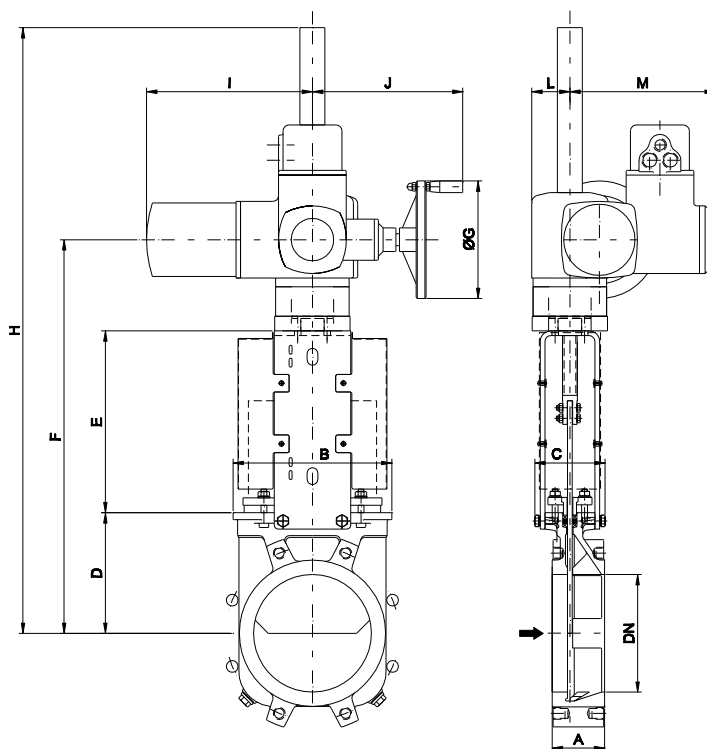





DN	A	B	C	D	E	F	ØG	H	I	J	L	M	sternØ x pitch	Torque(Nm)
50	46	124	100	105	129	337	160	547	265	249	62	238	20 x 4	10
65	46	139	100	115	146	404	160	574	265	249	62	238	20 x 4	10
80	64	154	100	124	162	429	160	599	265	249	62	238	20 x 4	10
100	64	174	100	140	187	470	160	640	265	249	62	238	20 x 4	10
125	70	192	100	150	211	504	160	674	265	249	62	238	20 x 4	15
150	76	217	100	170	237	550	160	1120	265	249	62	238	20 x 4	20
200	89	270	122	205	309	669	160	1289	265	249	62	238	25 x 5	30
250	114	326	170	240	364	759	160	1339	265	249	62	238	25 x 5	45
300	114	380	170	280	414	849	160	1434	265	249	62	238	25 x 5	40
350	127	438	170	320	500	950	200	1535	283	254	65	248	35 x 6	70
400	140	493	170	350	550	1030	200	1615	283	254	65	248	35 x 6	90
450	152	546	170	420	598	1193	200	1793	283	254	65	248	35 x 6	110
500	152	620	170	450	658	1283	200	1883	283	254	65	248	35 x 6	95
600	178	714	170	530	758	1463	315	2163	389	336	91	286	35 x 6	140

**FLANGE AND BOLTING DETAILS**

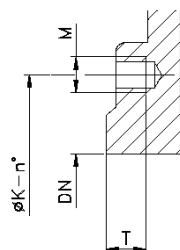
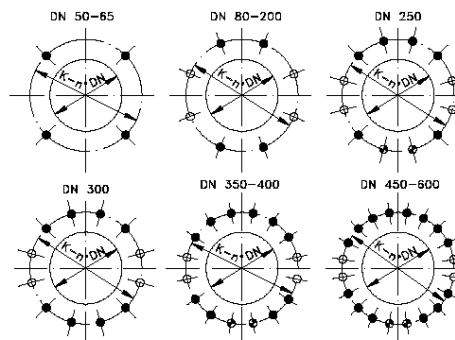

**EN 1092-2 PN10**

DN	K	n°	M	T	  
50	125	4	M-16	8	4 - 0 - 0
65	145	4	M-16	8	4 - 0 - 0
80	160	8	M-16	9	4 - 0 - 4
100	180	8	M-16	11	4 - 0 - 4
125	210	8	M-16	11	4 - 0 - 4
150	240	8	M-20	14	4 - 0 - 4
200	295	8	M-20	14	4 - 0 - 4
250	350	12	M-20	18	6 - 2 - 4
300	400	12	M-20	18	8 - 0 - 4
350	460	16	M-20	22	10 - 2 - 4
400	515	16	M-24	21	10 - 2 - 4
450	565	20	M-24	22	14 - 2 - 4
500	620	20	M-24	22	14 - 2 - 4
600	725	20	M-27	24	14 - 2 - 4



-  BLIND TAPPED HOLES
-  TAPPED THROUGH
-  THROUGH HOLES

**ANSI B16.5, class 150**

DN	K	n°	M	T	  
2"	4 3/4"	4	5/8" - 11 UNC	5/16"	4 - 0 - 0
2 1/2"	5 1/2"	4	5/8" - 11 UNC	5/16"	4 - 0 - 0
3"	6"	4	5/8" - 11 UNC	3/8"	4 - 0 - 0
4"	7 1/2"	8	5/8" - 11 UNC	7/16"	4 - 0 - 4
5"	8 1/2"	8	3/4" - 10 UNC	7/16"	4 - 0 - 4
6"	9 1/2"	8	3/4" - 10 UNC	9/16"	4 - 0 - 4
8"	11 3/4"	8	3/4" - 10 UNC	9/16"	4 - 0 - 4
10"	14 1/4"	12	7/8" - 9 UNC	11/16"	6 - 2 - 4
12"	17"	12	7/8" - 9 UNC	11/16"	8 - 0 - 4
14"	18 3/4"	12	1" - 8 UNC	7/8"	6 - 2 - 4
16"	21 1/4"	16	1" - 8 UNC	13/16"	10 - 2 - 4
18"	22 3/4"	16	1 1/8" - 7 UNC	7/8"	10 - 2 - 4
20"	25"	20	1 1/8" - 7 UNC	7/8"	14 - 2 - 4
24"	29 1/2"	20	1 1/4" - 7 UNC	15/16"	14 - 2 - 4

